

CM 708 M

VAN DAM

DRY OFFSET PRINTING MACHINE FOR DECORATION OF ROUND CUPS



“THE PROFESSIONAL PRINTER”

Van Dam has split up the printing machine in modules like; printing unit, in-feed, take-off etc (modular building concept). The advantage of this concept is that the customer can compose the machine according to his requirements.

After composing the machine configuration, it can be extended with a variety of options to shorten the change over time, to enhance printing quality and to reduce scrap and solvent usage. It's also possible to trade-in and upgrade the old configuration to new modules. The result is a flexible workhorse with a stable high performance level.



Van Dam Machine Europe B.V. Computerweg 21 • 1033 RH Amsterdam • The Netherlands

Van Dam Machine Corporation 1640 Regency Center Dr. • Macomb Township • Michigan 48042 • USA

info@vandammachine.com • www.vandammachine.com

CM 708 M OPTIONS

- Quick changeover set
- Roller set
- Roller wagon
- Upgrade to screw take off system
- Upgrade to feeder tube Ø 160 mm
- Upgrade to feeder Ø 205 mm
- Belt feeder instead of L-frame tray feeder
- A-frame tray feeder instead off L-frame tray feeder
- Stand alone cooling system instead of factory water cooling
- Hold-on
- Mandrel set up tool
- Scrap reduction system (SRS)
- 3rd form roller
- IMS (Ink Management System)
- Cabinet lighting
- Indexing packing table
- Screw separator
- Air jet separator
- Screw counting-restacker
- Transformer
- Power supply control
- Gas flame system instead of Corona
- Inline spot background color
- Double eject restacker to packer
- Metal detection
- Exchangeable ink tray for quick design change over



MACHINE FEATURES AND BENEFITS

- Up to 8 colors
- Electrical Direct Drive
- Width range of products (diameter 50 - 220 mm)
- Production speed up to 700 cups per minute
- High printing quality
- Modular building concept
- Reliable and proven technology
- Operator friendly
- All color heads are identical
- Well proven color heads, based on decades of manufacturing experience
- Color heads are prepared for cooling
- Sharp print results with two form rollers on each color head
- Magnetic plate cylinders
- Quick Set Ink Fountain (QSIF)
- All pressure and register adjustment can be made while printer is running
- Easy access to product handling areas and print area
- Modular building concept and wide range of options, for now and for the future
- Swing-open construction of color heads for easy access of rollers and plate cylinders
- Remote diagnostics with modem
- Siemens operator panel
- Belt feeder with pressure control
- Corona pre-treatment
- Quick change mandrel disc assembly, usable on all Van Dam cup printers
- Mandrel rotation control
- No cup no print system
- Double cup detection
- Pinhole detection and eject
- 'Curing on Mandrel' UV-lamp system with stand-by mode
- Belt take off
- Laser exact counting restacker with packing table

STANDARD SPECIFICATIONS

Min. / max. product height

- 30 - 200 mm

Min. / max. rim diameter

- 50 - 205 mm (optional 220 mm)

Max. printing height

- 150 mm

Max. printing length

6 blanket mode magnetic

- 498 mm

Max. printing length

3 blanket mode magnetic

- 610 mm

Min. / max. taper

- 0 - 12°

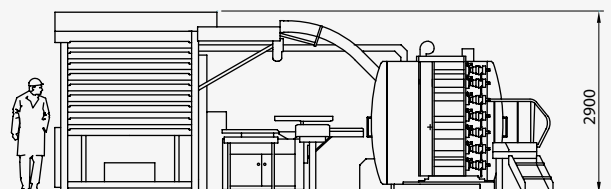
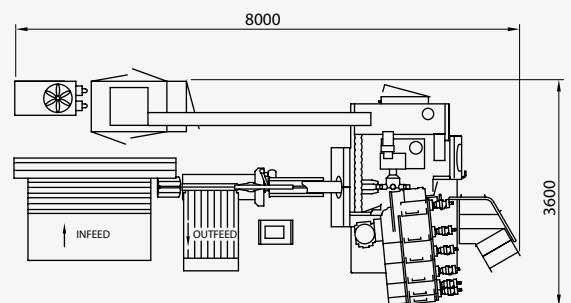

Product dimensions within above specifications are to be examined for print and speed efficiency. Standard product specifications can be modified upon special request. All specifications are subject to change without prior notice.